

X axis | 100A7

Amplified Piezo Actuators



Characteristics >>

- X Contraction
- Displacement to 100 μ m
- Fast response
- High resonant frequency
- Various models are available

Applications >>

- Probe scanning
- Fiber stretching
- Micro-scanning
- Flow measurement technology
- Optical mirrors positioning
- Diamond turning
- laser cavity tuning
- Inkjet technology

Introduction

The amplified piezo actuator is an actuator that amplifies and outputs the displacement generated by low-voltage piezo stacks preloaded by a mechanical amplifying structure.

The amplified structure is a mechanical shell, and its material is generally steel. In addition to providing optimized pre-tightening force for piezo stacks, it also protects piezo stacks from tensile forces that can cause irreversible or even fatal damage to piezo stacks.



Harbin Core Tomorrow Science & Technology Co., Ltd.

Tel: +86-451-86268790

Email: info@coremorrow.com

Headquarters: Building I2, No.191 Xuefu Road, Nangang District, Harbin

Fax: +86-451-86267847

Web: www.coremorrow.com

Shanghai Office: Building 2, No.608 Shengxia Road, Pudong District, Shanghai

Technical Data >>

Type	100A7	Units
Active axes	X	
Travel range ^[1]	100	$\mu\text{m}\pm 20\%$
Blocking force	155	N
Unloaded resonant frequency	1950	$\text{Hz}\pm 20\%$
Stiffness	1.55	$\text{N}/\mu\text{m}\pm 20\%$
El. capacitance	7.2	$\mu\text{F}\pm 20\%$
Material	Steel	
Operating temperature ^[2]	-20~80	$^{\circ}\text{C}$
Cable length ^[3]	0.15	$\text{m}\pm 10\text{mm}$
Voltage connector ^[3]	Bare wire	

Note: Unless otherwise specified, the above parameters are measured at room temperature about 25°C.

[1] Nominal Stroke at 0~150V, Max. stroke at -20~150V. Recommended voltage 0~120V for long-term and high-reliable operation.

[2] Custom ultralow temperature and ultrahigh vacuum versions are available.

[3] Custom cable length and connector is available.

Note: The parameters mentioned above are related to the test environment and test equipment.

Principle >>

Piezo stacks produce deformation and displacement along the main axis, that is, the long axis direction, and the elliptical mechanical structure amplifies and outputs the displacement along the short axis direction.

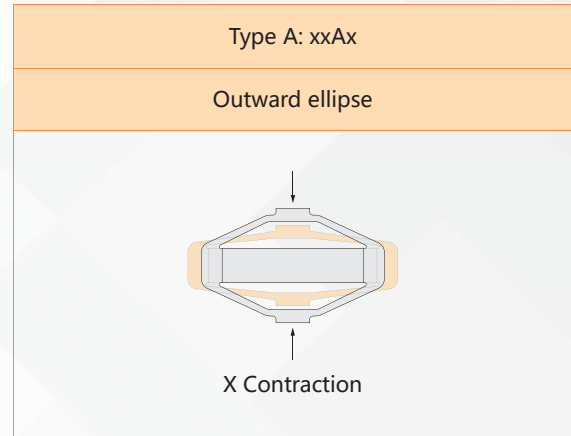

Drawing >>

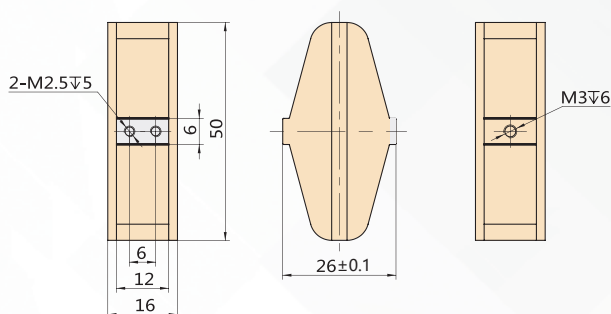

Recommended Controllers >>



E01.C1
 LCD, membrane button, up to 625mA
 RS-232/RS-422/USB interface
 Software secondary development



E53.C
 Small size, 60mA
 RS-232/RS-422/USB interface
 Software secondary development



Harbin Core Tomorrow Science & Technology Co., Ltd.

Tel: +86-451-86268790

Email: info@coremorrow.com

Headquarters: Building I2, No.191 Xuefu Road, Nangang District, Harbin

Fax: +86-451-86267847

Web: www.coremorrow.com

Shanghai Office: Building 2, No.608 Shengxia Road, Pudong District, Shanghai