

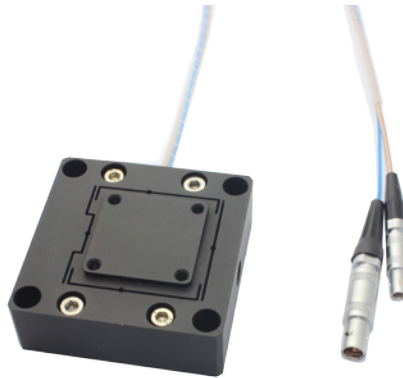

XP-62X Piezo Nanopositioning Stage

User Manual

Version: V1.0



This document describes the following products:

- XP-620
- XP-621
- XP-623

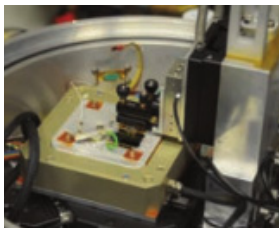

DECLARATION

Thank you for choosing CoreMorrow's products!

This user manual is applicable to XP-62X series piezo nanopositioning stage. For your smooth and correct use of this product, please read this manual carefully before use. Please follow the instructions in the manual installation and use procedures. Improper operation may cause injury to the operator or damage to the product. Therefore, the entire installation and operation process should be completed by a professional with a certain foundation and understanding of the product principle, or under the guidance of a professional.

If the product is disassembled or modified without permission, our company will not be responsible for any consequences arising therefrom.

It is illegal to change the product model and other false sales of our products. Users are advised to be vigilant. Once you find out or be deceived, contact us directly, we will crack down on illegal activities and prevent deception and economic losses. CoreMorrow will certainly investigate legal responsibility of the illegal subject and related parties.

With the continuous development and innovation of technology, we will add the latest information to the manual as needed without notice. Please contact us if you need any information.

Contents

1. Introduction	2
1.1 Purpose and content	2
1.2 Symbol and meaning.....	2
1.3 Expected reader.....	2
1.4 Manual lost replacement	2
2. Safety Guide.....	3
3. Product Overview	4
3.1 Product Introduction	4
3.2 Product Features	5
3.3 Motion direction	5
4. Operating environment	6
5. Installation and operation.....	6
5.1 Installation and connection	7
5.2 Load	7
5.3 Operating.....	10
6. Transportation and inspection	11
6.1 Transportation.....	11
6.2 Unpacking inspection.....	11
7. Maintenance and processing.....	12
7.1 Problem Processing	12
7.2 Daily maintenance	13
8.Customer Service	13
9.Contact us.....	14

1. Introduction

1.1 Purpose and content

- ▶ The manual is mainly for your smooth and correct use of piezo stage.
- ▶ The manual contains all necessary information for XP-62X series piezo stage.
- ▶ The manual describes the precautions during installation and use.

1.2 Symbol and meaning



DANGER: Improper handling may could cause injury to the operator.



Attention: Improper handling can cause damage to the equipment.

- ▶ No order between items.
 1. Please operating in order.
 - 2.

1.3 Expected reader

The manual default user has knowledge of piezo stages and controllers, and has a basis for its installation and use.

1.4 Manual lost replacement

If the manual is accidentally lost, please contact our customer service department, we will send you the latest version of user manual.

2. Safety Guide

XP-62X piezo nanopositioning stage is designed with advanced technology and safety standards, for safety and proper use of the product, please pay attention to following points when using:



Temperature changed and pressure will charge the piezo stage. Piezo stage will remain charged for a period of time disconnected from the controller, so the operator should pay attention when using it:

- ▶ Do not disassemble XP-62X piezo stage;
- ▶ Discharge XP-62X piezo stage before installation, it could be achieved by connecting to the controller;
- ▶ Do not pull out the controller during operation;
- ▶ Before using, please check whether the connecting wire of the product is in good condition, whether the product and the controller are effectively protected from grounding, in case of danger, please strictly regulate the operation during operation, do not touch it (up to 150V voltage) after power on.



In order to prevent damage to the product caused by improper operation, please pay attention to following points when using:

- ▶ XP-62X piezo stage is used as much as possible in dust-free, oil-free, lubricant-free environments;
- ▶ Since the product adopts flexible structure design, it is recommended that the load not exceed the bearing capacity of the product. Pay attention to the torque when loading. Do not twist or twist the load surface to avoid damage to the structure;
- ▶ Recommended voltage 0~120V for long-term operation to extend lifetime;
- ▶ Do not disassemble the product to avoid product damage;
- ▶ Avoid stretching and bending the cable interface to prevent damage to the cable;
- ▶ Please use the dedicated cable provided by us to connect the piezo stage and piezo controller;
- ▶ Please do not use cable extension wire, if need longer cable, please contact us.

3. Product Overview

3.1 Product Introduction

XP-62X piezo nanopositioning stage has the following advantages:

▶ High performance piezo stack:

XP-62X piezo stage is driven by high-performance piezo stack. The piezo stage is fully insulated, so its performance and service life are far superior to those of conventional stage. The insulating layer could effectively prevent the piezo stack from being damaged by moisture. The stability of piezo stack could be ensured under extreme conditions. The piezo stage has the characteristics of no rebound, no wear.

▶ Flexible hinge structure:

XP-62X adopts flexible hinge mechanism, which has the advantages of no friction and high positioning accuracy. The flexible hinge is a component that is not affected by static and dynamic friction. It is based on the elastic deformation of solid (such as steel) and has no rolling and sliding parts. With high stiffness and load carrying capacity, the hinge guides are maintenance-free and wear-free. Suitable for a wide range of temperatures without the need for lubricants.

▶ SGS sensor:

SGS sensor detects position information by expanding, they are fixed at appropriate positions in transmission portion, and the displacement is measured.

XP-62X piezo nanopositioning stage adopts frictionless flexible hinge guiding mechanism and has the characteristics of high rigidity, high resolution and fast response time. XY, XYZ versions could be available through adapter.

XP-62X is mainly used in biotechnology, interferometry, quality inspection, optical detection, nanopositioning, microscopy and imaging, image processing and other fields, and has very good development prospects.

3.2 Product Features

- ▷ Quick response time
- ▷ Closed-loop SGS sensor with high positioning accuracy
- ▷ Mainly used for high frequency

3.3 Motion direction

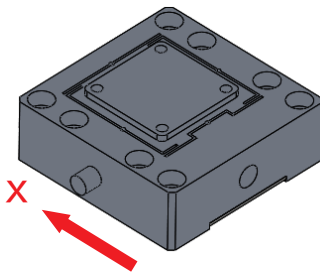

X motion

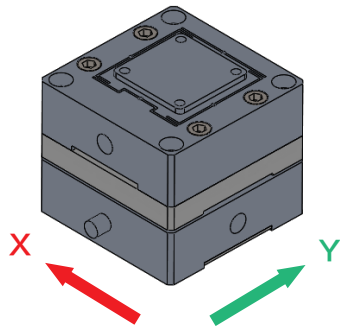

XY motion

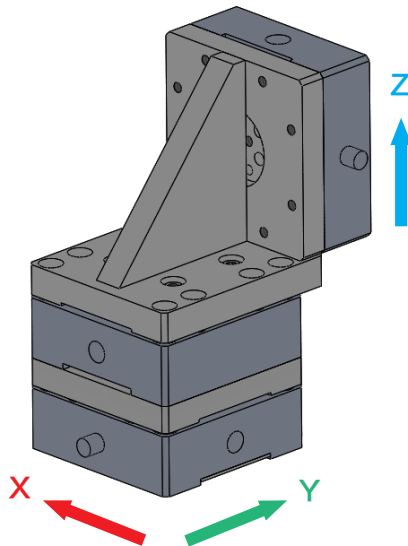

XYZ motion

XP-62X connection mark and motion direction are as follows:

Model	Motion direction	Description	Connection Mark
XP-62X X axis	X	Drive cable	CH1
		Sensor cable	1
XP-62X XY axes	X	Drive cable	CH1
		Sensor cable	1
	Y	Drive cable	CH2
		Sensor cable	2
XP-62X XYZ axes	X	Drive cable	CH1
		Sensor cable	1
	Y	Drive cable	CH2
		Sensor cable	2
Z	Drive cable	CH3	
	Sensor cable	3	

4. Operating environment

- ▷ Operating temperature: -20~80°C
- ▷ Environment free of dust, clean, and non-corrosive substances
- ▷ Relative humidity: <60%
- ▷ Recommended voltage between 0~120V for long-term and high-reliability operation

5. Installation and operation

Before installation, first check the safety, such as whether the cable is damaged or broken, and whether the power supply has grounding protection.

5.1 Installation and connection

1. Ensure that the installation plane is flat.
2. Secure the piezo stage with M4 screws and tighten.
3. Install the load and tighten properly to ensure positioning accuracy.
4. Connect the cable to the corresponding interface of the controller according to the connector head.

XP-62X installation diagram is as follows:

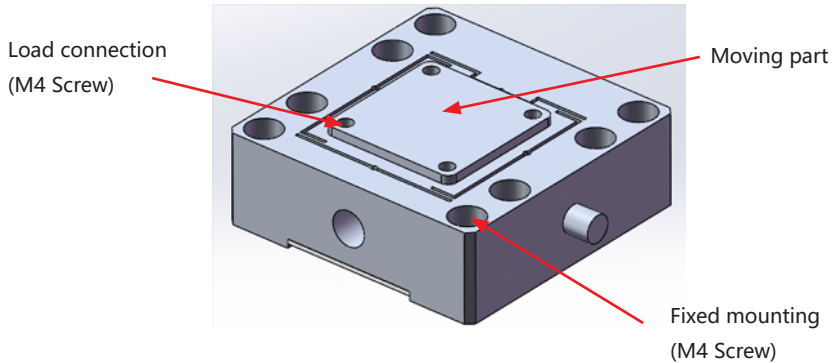

5.2 Load

When installing the load, ensure that the load mass is less than the max load of XP-62X, and install the load as much as possible at the center of the moving surface.

The correct placement of the load is shown below:

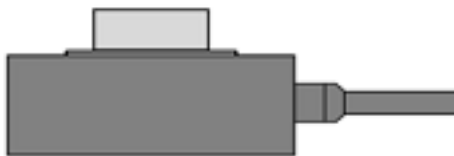

Load applied to the center of the stage

For protection, we don't recommend the load is too high. If it is used a higher load, please reduce the position center of the load gravity. The error placement method is as follows:

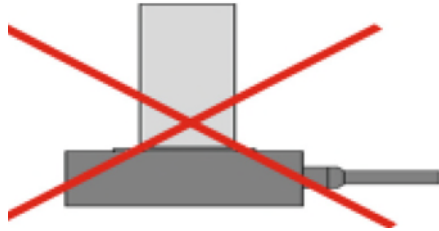

Try not to let the load center of gravity exceed the stage

It is forbidden to load the load on one side of the piezo stage, which would cause serious damage to the product, as shown in the following figure:

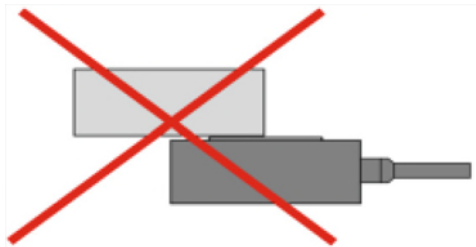

Do not load longer loads and add to the side of the piezo stage

If the screws used in tightening and connecting are too long, the screws will not be installed or some of screws will leak out, which will scratch the stage and affect the motion accuracy. If the screws are too short, the connection will not be compact and easy to

loosen. Looseness could damage the internal structure of the stage.

We recommend using the connection method shown below:

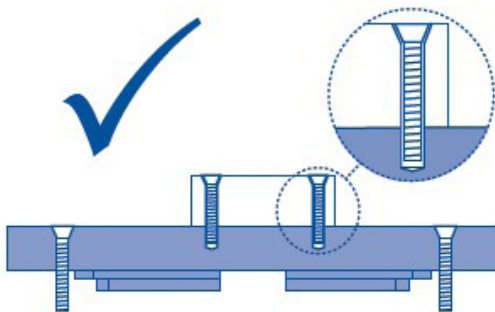

Correct connection

Please do not connect as shown below:

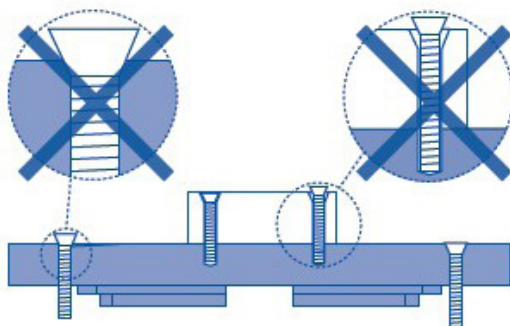

Incorrect connection

Note:

- ▶ Slowly tighten the load when installing it, and the torque should not be too large to avoid damage to mechanism.
- ▶ Avoid stretching and bending cables.
- ▶ Please connect XP-62X piezo nanopositioning stage and controller with special cable provided by CoreMorrow.
- ▶ Please do not extend the cable without authorization, please contact us if you need a longer cable.

5.3 Operating

Please confirm the following information before starting the power supply:

- ▶ XP-62X piezo nanopositioning stage has been grounded.
- ▶ The environment meets requirements of XP-62X working environment.
- ▶ The fixing screws must be tightened.

The above information is determined to perform controller related operations:

1. Please carefully read piezo controller user manual before operating, then start the controller;
2. Set the piezo controller to zero;
3. After checking for no abnormalities, input voltage values according to requirements (keyboard or analog control);
4. It could work normally within the rated voltage range of piezo ceramic (0~120V, max not exceeding 150V);
5. Please set the piezo controller to zero after used.

Please do not touch the product during the operation, avoid affecting the piezo stage performance or even damage the piezo stage.

The resolution of piezo ceramic is not limited. It depends on the performance of piezo controller. In order to better achieve the motion accuracy, it is recommended to use CoreMorrow piezo controller. For the operation of piezo controller, please refer to piezo controller usual manual.

Note:

- ▶ Please do not remove the grounding protection during operation. If it needs to be temporarily removed, reconnect the grounding protection before starting again.
- ▶ Drive voltage should not exceed 150V;
- ▶ If abnormal noise or oscillation occurs during operating, immediately turn off the power check parameter setting.

 **6. Transportation and inspection** 

6.1 Transportation

Piezo stage is packed in carton. The transportation is carried out under the condition of packaging. This product can be transported by various means of transportation under normal conditions. During transportation, it should avoid direct rain and snow, avoid contact with corrosive substances, and avoid strong collision, try to avoid improper behavior such as squeezing, irregular placement.

6.2 Unpacking inspection

Please check below information:

- ▶ Before opening the package, please carefully check the packaging for damage, bruising, wetting, moisture, deformation, etc.
- ▶ Please check the parts on a case-by-case basis based on the supply contract and the packing list
 - ▶ Whether there is obvious damage on the surface of the product
 - ▶ Whether the product identification is clear and complete
 - ▶ Whether the connector is loose, the connection line is broken or not, etc.

If any of the above occurs, please make a detailed record and take a photo, and please contact us immediately

Precautions:

- ▶ Please handle gently when unpacking to avoid permanent damage to the stage

caused by bumps

- ▶ Please do not use heavy tools or use rough methods to open them
- ▶ Please do not discard all packaging materials for return shipments

7. Maintenance and processing

7.1 Problem Processing

Common problems are shown in the following table:

Problem Description	Possible reasons	Solutions
No displacement or displacement becomes smaller	The cable is not connected correctly or is in faulty contact.	Check the cable connection
	Excessive load	Loaded by product max load
	Sensor zero drift	Calibrate the sensor
Reduced accuracy	The installation base is uneven	Mount the stage on flat surface
	Loose connection	Fastening connection
	Wiring is wrong	Check the wiring is correct
Vibration or inaccurate positioning at start-up	The parameters are incorrect.	Stop immediately, check the parameter settings
	Resonance	operating frequency less than the resonant frequency

If the user has problems that could not be solved. Please record the fault situation and contact with us. The professional technical engineer would help solve the problem.

Problems caused by improper operation are not covered by the warranty;

CoreMorrow is not responsible for any problems caused by dismantling the piezo stage without permission.

7.2 Daily maintenance

If the piezo stage is not used for a long time, please store it in a room environment with no dust, good ventilation, clean and non-corrosive substances.

Please do not loosen the screws on the stage structure, avoiding to affect the accuracy of the stage.

Daily cleaning:

Please disconnect the piezo stage to controller, then clean the surface of it.

When cleaning, first wipe a small amount of detergent with a towel and gently wipe the surface of the piezo stage, then wash it with alcohol. Please do not use ultrasonic waves for cleaning.

When cleaning the surface, try not to pick up the product. If it is necessary to pick up, please place a sponge under the piezo stage for protection, the piezo stage should not be too high from the sponge to prevent the piezo stage from falling off.

8. Customer Service

If you have questions about the products you are currently using, please let us know the following information:

- ▶ Piezo stage model number and related number
- ▶ Controller model for this product
- ▶ Software driver version for this product
- ▶ Computer operating system for installing supporting software

9. Contact us

CoreMorrow Ltd.

Tel: +86-451-86268790

Email: info@coremorrow.com

Website: www.coremorrow.com

Address: Building I2, No.191 Xuefu Road, Nangang District, Harbin, HLJ, China

CoreMorrow Official and CTO WeChat are below:

