

# P72 Piezo Objective Scanner

## User Manual

Version: V1.0



This document describes the following products:

- P72.Z100K
- P72.Z100S

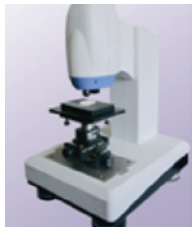
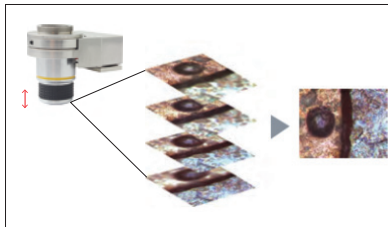
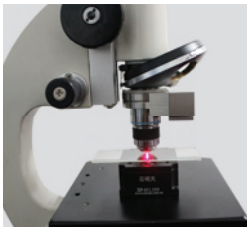

# DECLARATION

Thank you for choosing Coremorrow' s products!

This user manual is applicable to P72 series piezo objective scanner. For your smooth and correct use of this product, please read this manual carefully before use. Please follow the instructions in the manual installation and use procedures. Improper operation may cause injury to the operator or damage to the product. Therefore, the entire installation and operation process should be completed by a professional with a certain foundation and understanding of the product principle, or under the guidance of a professional.

If the product is disassembled or modified without permission, our company will not be responsible for any consequences arising therefrom.

It is illegal to change the product model and other false sales of our products. Users are advised to be vigilant. Once you find out or be deceived, contact us directly, we will crack down on illegal activities and prevent deception and economic losses. CoreMorrow will certainly investigate legal responsibility of the illegal subject and related parties.

With the continuous development and innovation of technology, we will add the latest information to the manual as needed without notice. Please contact us if you need any information.

# Contents

1. Introduction .....	2
1.1 Purpose and content .....	2
1.2 Symbol and meaning.....	2
1.3 Expected reader.....	2
1.4 Manual lost replacement .....	2
2. Safety Guide.....	3
3. Product Overview .....	4
3.1 Product Introduction .....	4
3.2 Features .....	4
3.3 Motion direction .....	5
4. Operating environment .....	5
5. Installation and operation.....	6
5.1 Installation and connection .....	6
5.2 Loading.....	7
5.3 Operating.....	7
6. Transportation and inspection .....	8
6.1 Transportation.....	8
6.2 Unpacking inspection.....	8
7. Maintenance and processing.....	9
7.1 Problem Processing .....	9
7.2 Daily maintenance .....	9
8. Customer Service .....	10
9. Contact us.....	10

## 1. Introduction

### 1.1 Purpose and content

The manual is mainly for your smooth and correct use of piezo objective scanner.

The manual contains all necessary information for P72 piezo objective scanner.

The manual describes the precautions during installation and use.

### 1.2 Symbol and meaning



**DANGER:** Improper handling may could cause injury to the operator.



**Attention:** Improper handling can cause damage to the equipment.

▶ No order between items.

1. Please operating in order.
- 2.

### 1.3 Expected reader

The manual default user has knowledge of piezo objective scanners and controllers, and has a basis for its installation and use.

### 1.4 Manual lost replacement

If the manual is accidentally lost, please contact our customer service department, we will send you the latest version of user manual.

## 2. Safety Guide

P72 piezo objective scanner is designed with advanced technology and safety standards, for safety and proper use of the product, please pay attention to following points when using:



Temperature changed and pressure will charge the piezo objective scanner. It will remain charged for a period of time disconnected from the controller, so the operator should pay attention when using it:

- ▶ Do not disassemble P72 piezo objective scanner;
- ▶ Discharge P72 piezo objective scanner before installation, it could be achieved by connecting to the controller;
- ▶ Do not pull out the controller during operation;
- ▶ Before using, please check whether the connecting wire of the product is in good condition, whether the product and the controller are effectively protected from grounding, in case of danger, please strictly regulate the operation during operation, do not touch it (up to 150V voltage) after power on.



In order to prevent damage to the product caused by improper operation, please pay attention to following points when using:

- ▶ P72 piezo objective scanner is used as much as possible in dust-free, oil-free, lubricant-free environments;
- ▶ Since the product adopts flexible structure design, it is recommended that the load not exceed the bearing capacity of the product. Pay attention to the torque when loading. Do not twist or twist the load surface to avoid damage to the structure;
- ▶ Recommended voltage 0~120V for long-term operation to extend lifetime;
- ▶ Do not disassemble the product to avoid product damage;
- ▶ Avoid stretching and bending the cable interface to prevent damage to the cable;
- ▶ Please use the dedicated cable provided by us to connect the piezo objective scanner and piezo controller;
- ▶ Please do not use cable extension wire, if need longer cable, please contact us.

## 3. Product Overview

### 3.1 Product Introduction

P72 Piezo objective scanner has the following advantages:

▷ High performance piezo stack:

P72 is driven by high-performance piezo stack. It is fully insulated, so its performance and service life are far superior to conventional actuator. Insulating layer can effectively prevent piezo stack from being damaged by moisture. Stability of piezo stack could be ensured under extreme conditions. It has the characteristics of no rebound, no wear.

▷ Flexible hinge structure:

P72 adopts flexible hinge mechanism, which has advantages of no friction and high positioning accuracy. Flexible hinge is based on the elastic deformation of solid and has no rolling and sliding parts. With high stiffness and load capacity, the hinge guides are maintenance-free and wear-free.

▷ SGS sensor:

SGS sensors detect position information by their own expansion. They are fixed at the proper position of the transmission part and measure the displacement of the moving part. This type of position measurement is made by contact and indirect measurement. Therefore the displacement of piezo scanner is measured by measuring levers, guide hinges or piezoe stacks.

P72 piezo objective scanner is small-size, high-precision positioner with Z-axis linear motion range of up to 100 $\mu$ m. It adopts flexible hinge design, which has high friction-free, yaw-free, closed-loop control positioning accuracy. Separate screw adapter design, can be adapted to a variety of microscopes.

### 3.2 Features

- ▷ SGS sensor, more accuracy;
- ▷ Good focusing stability;
- ▷ Various adapter models are available.

### 3.3 Motion direction

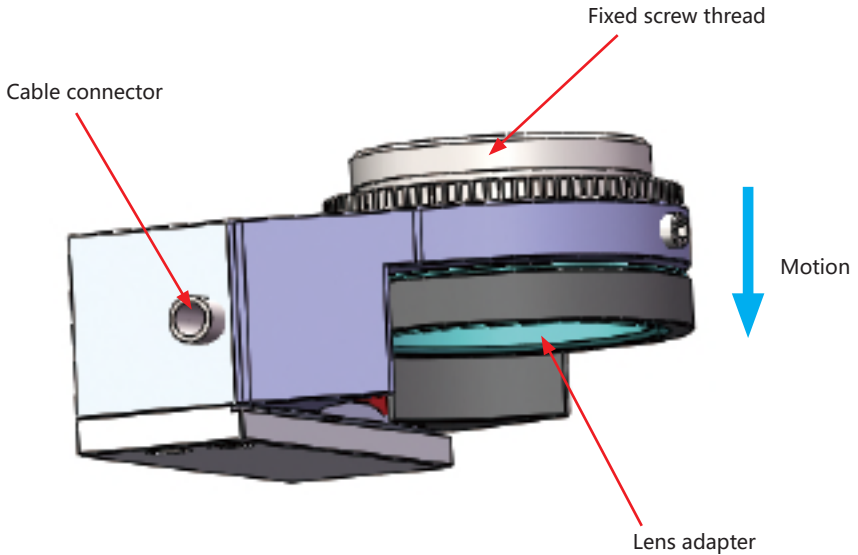

Figure 1. P72 Piezo Objective Scanner

## 4. Operating environment

- ▶ Operating temperature: -20~80°C
- ▶ Environment free of dust, clean, and non-corrosive substances
- ▶ Relative humidity: <60%
- ▶ Recommended voltage between 0 and 120V for long-term and high-reliability operation.

## 5. Installation and operation

### 5.1 Installation and connection

Before installation, first check the safety, such as whether the cable is damaged or broken, and whether the power supply has grounding protection.

Installation steps of P72, as follows:

1. Screw the corresponding objective lens into the P72 objective scanner and tighten;
2. Tighten the assembled objective lens locator and the microscope connection end;

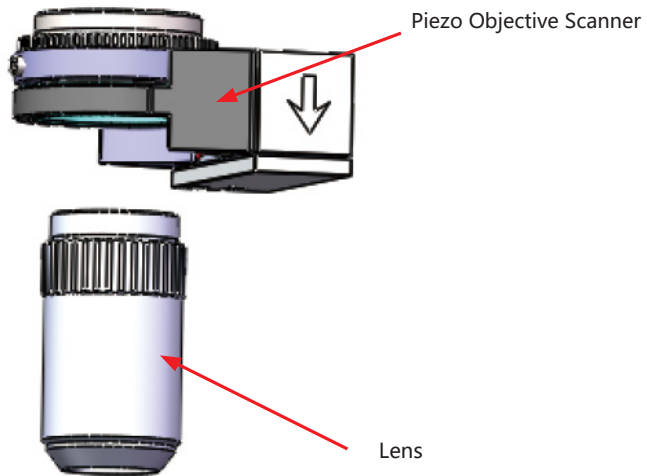

Figure2. P72 Installation diagram

Note:

- ▶ During the installation process, please pay attention to handle, so as not to damage the P72 piezo objective scanner or scratch and wear it.
- ▶ When connecting P72, it is required that the weight of the objective lens does not exceed the maximum allowable load of P72.



## 5.2 Loading

Connect the load according to the placement method described below, as shown in the figure below:

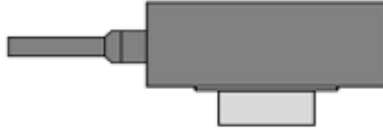

Figure3. Correct loading method

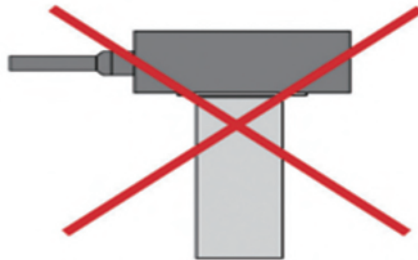

Figure4. Incorrect loading method

When connecting the objective lens, pay attention that the quality of the objective lens does not exceed the maximum allowable load of P72, and the load is not too long, otherwise it is easy to cause oscillation and damage P72.

## 5.3 Operating

Please confirm the following information before starting the power supply:

- ▶ The environment meets requirements of P72 working environment;
- ▶ The fixing screws must be tightened;

The above information is determined to perform controller related operations:

- 1、 Please carefully read piezo controller user manual before operating, then start the controller;
- 2、 Set the piezo controller to zero;
- 3、 After checking for no abnormalities, input voltage values according to requirements (keyboard or analog control);
- 4、 It could work normally within the rated voltage range of piezo ceramic (0~120V, max not exceeding 150V);
- 5、 Please set the piezo controller to zero after used.

Please do not touch the product during the operation, avoid affecting the piezo scanner performance or even damage the piezo scanner.

The resolution of piezo ceramic is not limited. It depends on the performance of piezo controller. In order to better achieve the motion accuracy, it is recommended to use CoreMorrow piezo controller. For the operation of piezo controller, please refer to piezo controller usual manual.

## 6. Transportation and inspection >>

### 6.1 Transportation

Piezo Objective scanner is packed in carton. The transportation is carried out under the condition of packaging. This product can be transported by various means of transportation under normal conditions. During transportation, it should avoid direct rain and snow, avoid contact with corrosive substances, and avoid strong collision, try to avoid improper behavior such as squeezing, irregular placement.

### 6.2 Unpacking inspection

Please check below information:

- ▶ Before opening the package, please carefully check the packaging for damage, bruising, wetting, moisture, deformation, etc.;
- ▶ Please check the parts on a case-by-case basis based on the supply contract and the

packing list;

- ▷ Whether there is obvious damage on the surface of the product;
- ▷ Whether the product identification is clear and complete;
- ▷ Whether the connector is loose, the connection line is broken or not, etc.;

If any of the above occurs, please make a detailed record and take a photo, and please contact us immediately.

Precautions:

- ▷ Please handle gently when unpacking to avoid permanent damage to the piezo objective scanner caused by bumps;
- ▷ Please do not use heavy tools or use rough methods to open them;
- ▷ Please do not discard all packaging materials for return shipments.

## 7. Maintenance and processing

### 7.1 Problem Processing

If the user has any problems during use, please record the failure in detail and contact us, and professional technicians will assist in solving it.

Problems caused by improper operation are not covered by the warranty;

CoreMorrow is not responsible for all problems caused by unauthorized disassembly of the product.

### 7.2 Daily maintenance

If the product will not be used for a long time, please pack and store it in indoor environment with no dust, good ventilation, cleanness and no corrosive substances.

Internal structure of the P72 is maintenance-free. Please do not loosen the screws on the product structure to avoid affecting the accuracy of the product.

#### **Daily cleaning:**

Please separate the product from the controller before cleaning the product surface.

When cleaning, first use a towel dipped in a small amount of detergent to gently wipe the

surface of the product, and then clean it with alcohol. Do not use ultrasonic cleaning.

When cleaning the surface, try not to pick up the product. If you must pick it up, it is better to place a sponge under the product for protection. The product should not be too high away from the sponge to prevent the product from being unstable and falling off.

### 8. Customer Service

If you have questions about the products you are currently using, please let us know the following information:

- ▷ Piezo objective scanner model number and related number
- ▷ Controller model for this product
- ▷ Software driver version for this product
- ▷ Computer operating system for installing supporting software

### 9. Contact us

#### **CoreMorrow Ltd.**

Tel: +86-451-86268790

Email: [info@coremorrow.com](mailto:info@coremorrow.com)

Website: [www.coremorrow.com](http://www.coremorrow.com)

Address: Building I2, No.191 Xuefu Road, Nangang District, Harbin, HLJ, China

**CoreMorrow Official and CTO WeChat are below:**

