

H60 Piezo Hexapod

User Manual

Version: V1.0

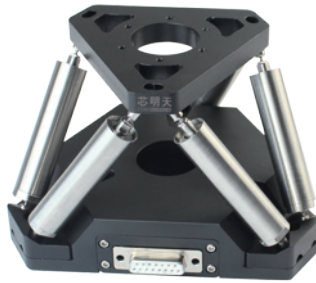

This document describes the following products:

- H60.XYZTR5S
- H60.XYZTR5K

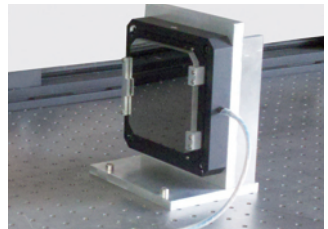
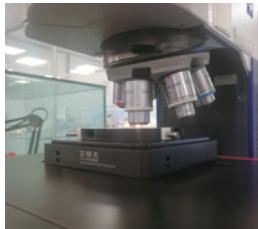
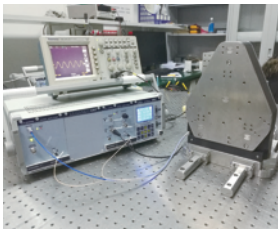

DECLARATION

This user manual is applicable to H60 piezo hexapod, for your smooth and correct use of this product, please read this manual carefully before using it. Please follow the instructions in the installation and use process. Improper operation may cause injury to the operator and/or damage to the product, so it is required that the entire installation and operation process should be completed by professionals with a certain foundation and a certain understanding of product principles, or under the guidance of a professional.

If you disassemble or transform the product without permission, our company will not be responsible for any consequences arising therefrom.

To change the product model and other false sales of our company's products are illegal, users should be vigilant. Once found, you should actively report or contact our company, jointly crack down on illegal acts, and prevent fraud and economic losses. CoreMorrow will investigate for the legal responsibility of the illegal subject and related party.

With the continuous development and innovation of technology, CoreMorrow will timely add the latest information to the manual as required. If you need, please contact us, or to our website www.coremorrow.com for download, we apologize for any inconvenience caused to you.

Contents

1. Introduction	2
1.1 Purpose and content	2
1.2 Symbol and meaning.....	2
1.3 Users of This Manual	2
1.4 Manual Lost and Reissued.....	2
2. Safety Guide.....	3
3. Product Overview	4
3.1 Product Introduction	4
3.2 Product Features	5
4. Operating environment	5
5. Installation and operation.....	5
5.1 Installation and Precautions.....	5
5.2 Load.....	6
5.3 Operating.....	8
6. Transportation and inspection	9
6.1 Transportation.....	9
6.2 Unpacking inspection.....	9
7. Maintenance and processing.....	10
7.1 Problem Processing	10
7.2 Daily maintenance	11
8.Customer Service	11
9.Contact us.....	12

1. Introduction

1.1 Purpose and content

- ▶ The manual is mainly for smooth and correct use of H60 piezo hexapod.
- ▶ The manual contains all the necessary information for H60 piezo hexapod.
- ▶ Introduction of the precautions during installation and use.

1.2 Symbol and meaning



DANGER: Improper handling may could cause injury to the operator.



Attention: Improper handling can cause damage to the equipment.

- ▶ No order between items.

1. Please operating in order.
- 2.

1.3 Users of This Manual

The default user of this manual has knowledge of piezoelectric products and controllers, and has a certain basis for their installation and use.

1.4 Manual Lost and Reissued

If this manual is lost, please contact CoreMorrow. We will send you the latest version of the user manual.

2. Safety Guide

H60 piezo hexapod is designed with the most advanced technology and safety standards for your own safety and the correct use of the product, please observe the following points when in use.



A change in temperature and pressure will charge the piezoelectric stage, and the actuator will remain energized for a period of time when it is disconnected from the controller, so the operator should pay attention to when in use:

- ▶ Do not disassemble H60 piezo hexapod.
- ▶ Discharge H60 before installation, which can be done by connecting to the controller.
- ▶ Do not unplug the wire connecting with controller during operation.
- ▶ Before use, check whether the connection wire of the product is in good condition and whether the product and the controller are effectively grounded. During operation, strictly standardize the operation. Do not touch the product (up to 150V voltage) with your hand when power on, in case of danger.



In order to prevent damage to the product caused by improper operation, the following points should be paid attention to when in use.

- ▶ H60 piezo hexapod is used in a dust-free, oil-free and lubricant-free environment.
- ▶ As the product is designed with flexible structure, it is recommended that the load should not exceed load capacity of product. When loading, DO NOT apply torque force and DO NOT pry or twist the load surface, so as not to damage the structure.
- ▶ Recommended voltage range is 0~120V for long-term use and lifetime.
- ▶ Do not disassemble the product to avoid damage.
- ▶ Avoid stretching and bending the cable interface to prevent damage to the cable. Use the dedicated cable provided by CoreMorrow to connect H60 piezo hexapod Stage to controller.
- ▶ Do not connect via an extension cable casually, if you need a longer cable, please contact CoreMorrow.

3. Product Overview

3.1 Product Introduction

H60 piezo hexapod has the following advantages:

▶ High performance piezo stack:

H60 piezo hexapod is driven by a highly reliable ceramic actuator with a fully insulated structure, so its performance and service life are far better than the traditional actuator. The insulating layer can effectively prevent the piezoelectric ceramic from being damaged when exposed to moisture. Therefore, the stability of piezoelectric ceramics can be guaranteed under extreme circumstances. Compared with traditional driving mechanism, there are no transmission parts and friction. Therefore, ceramic actuator has the characteristics of no rebound, no maintenance, and no wear, etc.

▶ Flexible hinge structure:

H60 piezo hexapod adopts flexible hinge mechanism has advantages of no friction, high positioning accuracy. Flexible hinge is an element not affected by static and dynamic friction, based on the elastic deformation of metal material (e.g., steel) , there is no rolling and sliding parts. Flexible unit has very high load capacity and stiffness. Hinge guide needs no maintenance and no wear and tear. Suitable for a wide range of temperatures, no lubricating oil is required.

▶ Strain Sensor:

Strain sensor detects the position information by its own expansion. They are fixed in the proper position of the transmission part and measure the displacement of the moving part. This type of position measurement is made by contact and indirect measurement. So the displacement of the moving platform is measured by measuring lever, guide hinge, or piezoelectric ceramic stack.

H60 is a piezo stage with 6-axis motion of θ_x , θ_y , θ_z , X, Y, and Z. 6-axis movement in space is realized by the coordinated expansion and contraction of six piezoelectric actuators. Closed-loop version has high positioning accuracy.

3.2 Product Features

- ▶ Motion in X, Y, Z, θ_x , θ_y , θ_z
- ▶ Small coupling
- ▶ Closed-loop version for high accuracy

4. Operating environment

- ▶ A clean, dustfree and non-corrosive environment
- ▶ Operating temperature : -20~80°C
- ▶ Relative humidity : <60%
- ▶ Recommended voltage range is 0~120V for long-term use and lifetime

5. Installation and operation

Safety check should be carried out before installation, such as whether the connection wire is damaged or broken, whether the drive power supply is grounded, etc.

5.1 Installation and Precautions

1. Ensure that the installation plane is flat.
2. Secure the piezo stage with M4 screws and tighten.
3. Install the load and tighten properly to ensure positioning accuracy.
4. Connect the cable to the corresponding interface of the controller according to the connector head.

Installation diagram of H60 is as follows:

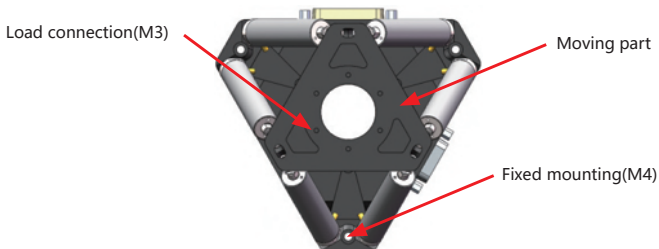

5.2 Load

When installing the load, ensure that the load mass is less than max load of H60, and install the load as much as possible at the center of the moving surface.

The correct placement of the load is shown below:

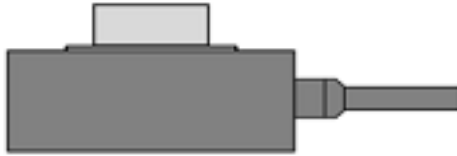

Load applied to the center of the stage

For protection, we don't recommend the load is too high. If it is used a higher load, please reduce the position center of the load gravity. The error placement method is as follows:

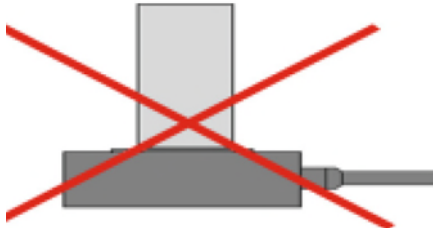

Try not to let the load center of gravity exceed the stage

It is forbidden to load the load on one side of the piezo stage, which would cause serious damage to the product, as shown in the following figure:

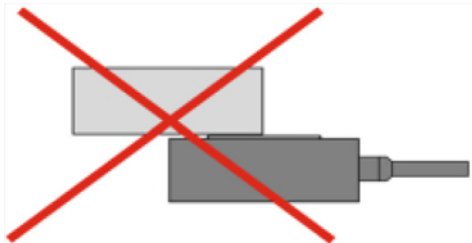

Do not load longer loads and add to the side of the piezo stage

If the screws used in tightening and connecting are too long, the screws will not be installed or some of screws will leak out, which will scratch the stage and affect the motion accuracy. If the screws are too short, the connection will not be compact and easy to loosen. Looseness could damage the internal structure of the stage.

We recommend using the connection method shown below:

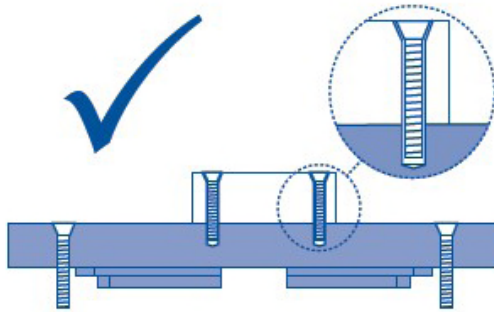

Correct connection

Please do not connect as shown below:

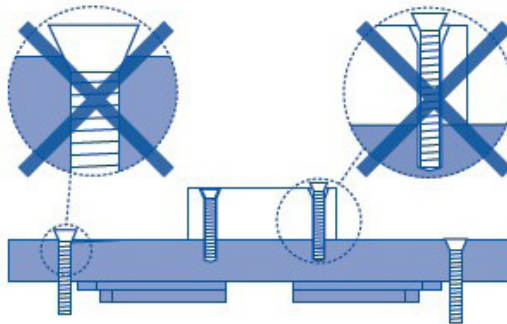

Incorrect connection

Note:

- ▶ Slowly tighten the load when installing it, and the torque should not be too large to avoid damage to mechanism.
- ▶ Avoid stretching and bending cables.
- ▶ Please connect H60 and controller with special cable provided by CoreMorrow.
- ▶ Please do not extend the cable without authorization, please contact us if you need a longer cable.

5.3 Operating

Please confirm the following information before starting the power supply:

- ▶ H60 has been grounded.
- ▶ The environment meets requirements of H60 working environment.
- ▶ The fixing screws must be tightened.

The above information is determined to perform controller related operations:

1. Please carefully read piezo controller user manual before operating, then start the controller;
2. Set the piezo controller to zero;
3. After checking for no abnormalities, input voltage values according to requirements (keyboard or analog control);
4. It could work normally within the rated voltage range of piezo ceramic (0~120V, max not exceeding 150V);
5. Please set the piezo controller to zero after used.

Please do not touch the product during the operation, avoid affecting the piezo stage performance or even damage the piezo stage.

The resolution of piezo ceramic is not limited. It depends on the performance of piezo controller. In order to better achieve the motion accuracy, it is recommended to use CoreMorrow piezo controller. For the operation of piezo controller, please refer to piezo controller usual manual.

Note:

- ▶ Please do not remove the grounding protection during operation. If it needs to be temporarily removed, reconnect the grounding protection before starting again.
- ▶ Drive voltage should not exceed 150V;
- ▶ If abnormal noise or oscillation occurs during operating, immediately turn off the power check parameter setting.

 **6. Transportation and inspection** **6.1 Transportation**

Piezo stage is packed in carton. The transportation is carried out under the condition of packaging. This product can be transported by various means of transportation under normal conditions. During transportation, it should avoid direct rain and snow, avoid contact with corrosive substances, and avoid strong collision, try to avoid improper behavior such as squeezing, irregular placement.

6.2 Unpacking inspection

Please check below information:

- ▶ Before opening the package, please carefully check the packaging for damage, bruising, wetting, moisture, deformation, etc.
- ▶ Please check the parts on a case-by-case basis based on the supply contract and the packing list
- ▶ Whether there is obvious damage on the surface of the product
- ▶ Whether the product identification is clear and complete
- ▶ Whether the connector is loose, the connection line is broken or not, etc.

If any of the above occurs, please make a detailed record and take a photo, and please contact us immediately.

Precautions:

- ▶ Please handle gently when unpacking to avoid permanent damage to the stage caused by bumps
- ▶ Please do not use heavy tools or use rough methods to open them
- ▶ Please do not discard all packaging materials for return shipments

7. Maintenance and processing

7.1 Problem Processing

Common problems are shown in the following table:

Problem Description	Possible reasons	Solutions
No displacement or displacement becomes smaller	The cable is not connected correctly or is in faulty contact.	Check the cable connection
	Excessive load	Loaded by product max load
	Sensor zero drift	Calibrate the sensor
Reduced accuracy	The installation base is uneven	Mount the stage on flat surface
	Loose connection	Fastening connection
	Wiring is wrong	Check the wiring is correct
Vibration or inaccurate positioning at start-up	The parameters are incorrect.	Stop immediately, check the parameter settings
	Resonance	operating frequency less than the resonant frequency

If the user has problems that could not be solved. Please record the fault situation and contact with us. The professional technical engineer would help solve the problem.

Problems caused by improper operation are not covered by the warranty;

CoreMorrow is not responsible for any problems caused by dismantling the piezo stage without permission.

7.2 Daily maintenance

If the piezo stage is not used for a long time, please store it in a room environment with no dust, good ventilation, clean and non-corrosive substances.

Please do not loosen the screws on the stage structure, avoiding to affect the accuracy of the stage.

Daily cleaning:

Please disconnect the piezo stage to controller, then clean the surface of it.

When cleaning, first wipe a small amount of detergent with a towel and gently wipe the surface of the piezo stage, then wash it with alcohol. Please do not use ultrasonic waves for cleaning.

When cleaning the surface, try not to pick up the product. If it is necessary to pick up, please place a sponge under the piezo stage for protection, the piezo stage should not be too high from the sponge to prevent the piezo stage from falling off.

8. Customer Service

If you have questions about the products you are currently using, please let us know the following information:

- ▶ Piezo stage model number and related number
- ▶ Controller model for this product
- ▶ Software driver version for this product
- ▶ Computer operating system for installing supporting software

9. Contact us

CoreMorrow Ltd.

Tel: +86-451-86268790

Email: info@coremorrow.com

Website: www.coremorrow.com

Address: Building I2, No.191 Xuefu Road, Nangang District, Harbin, HLJ, China

CoreMorrow Official and CTO WeChat are below:

