



E53.D Series Piezo Controller

User Manual

Version: V1.0



This document describes the following products:

- E53.D Servo 1 channel SGS sensor Software

DECLARATION

Declaration!

This user manual is a integrated user manual of the E53.D series piezoelectric controller. Please read this user manual carefully before using this controller. Follow the instructions in the manual during use. If there is any problem, please contact us for technical support. If you do not follow this manual or disassemble and modify the product yourself, the company will not be liable for any consequences arising therefrom.

Please read the following to avoid personal injury and to prevent damage to this product or any other product connected to it. In order to avoid possible hazards, this product can only be used within the specified range.

Notice!

Do not touch any exposed ends of the product and its accessories.

There is high voltage inside. Do not open the case without permission.

Do not connect or disconnect input, output, or sensor cables with power on.

Please keep surface of E53.D clean and dry, don't operate in humid or static environment.

After use, output voltage should be cleared to zero before turning off the controller switch, such as switching the servo state to the open-loop state.

Danger!

The piezoelectric power amplifier described in this manual is a high-voltage device capable of outputting high currents, which can cause serious or even fatal damage if not used properly.

It is strongly recommended that you do not touch any parts that connect to the high voltage output.

Special Note: If you connect it with other products in addition to our company, please follow the general accident prevention procedures.

Operating the high-voltage amplification requires training professional operators.

Warning!

If the voltage exceeds the PZT's tolerable range, it will cause permanent damage to the PZT. Before adding voltage to the PZT poles, it must be ensured that the positive and negative poles of the PZT are connected correctly and the operating voltage is within the allowable range of this PZT.

Cautious!

E53.D housing should be installed on a horizontal surface in an area with a 3CM air flow area to prevent internal convection in the vertical direction.

Insufficient airflow can cause equipment to overheat or premature instrument damage.

Contents

1.Security	2
1.1 Introduction	2
1.2 Safety Instructions	2
1.3 Notes	2
2. Introduction	3
2.1 Features	3
2.2 Applicaitons	3
2.3 Order information.....	3
3.Driving Principle	4
4.Power Calculation	4
5.Appearance	4
6.Panel Introduction	5
7.Notes and suggestions	6
8.Contact us	7

1.Security

1.1 Introduction

- ▶ Keep the surface of piezo controller clean and dry.
- ▶ Do not operate in the humid or static environment.
- ▶ Piezo controllers are used to drive capacitive loads (eg piezo actuators).
- ▶ It should not be used in user manuals of other products of the same name.
- ▶ Pay special attention that it cannot be used to drive resistive or inductive loads.
- ▶ Piezo controllers could be used for static and dynamic operating applications.

1.2 Safety Instructions

Piezo controller is based on the national safety standard. Improper use may cause personal injury or damage to the piezo controller. The operator is responsible for the correct installation and operation of the piezo controller.

- ▶ Please read the user manual in detail.
- ▶ Please eliminate any faults and potential safety hazards caused by the faults.

If the protective ground wire is not connected or connected incorrectly, there will be a possibility of leakage. If you touch the E53.D piezo controller, it may cause serious or even fatal injuries.

If the piezo controller housing is opened without permission, touching the live parts may cause electric shock, resulting in serious or even fatal injury or damage to the piezo controller.

▶ Only authorized professional technicians with corresponding qualifications could open the piezo controller.

- ▶ When opening the piezo controller housing, you need to disconnect the power plug.
- ▶ Do not touch any internal parts when operating under bare conditions.

1.3 Notes

▶ The contents in the user manual are all standard descriptions, and the customized parameters are not explained in detail in this manual.

▶ The latest user manual is available for download on CoreMorrow website.

▶ When operating the piezo controller, the user manual should be placed near the system for easy reference in time. If the user manual is missing or damaged, please contact CoreMorrow customer service department.

- ▶ Please promptly add all the information given in the manufacturer's user manual, such as

supplements or technical instructions.

- ▶ If your user manual is incomplete, a lot of important information will be missed, causing serious or fatal injury and causing property damage. Please read and understand the content in the user manual before installing and operating the piezo controller.
- ▶ Only professionals who are authorized to meet the technical requirements could install, operate, maintain and clean the piezo controllers.

2. Introduction

2.1 Features

- ▶ 1 channel small size
- ▶ 24V (20~30V) 1.5A 36W
- ▶ Peak current 1A
- ▶ Ave current 60mA
- ▶ Unload bandwidth 10KHz
- ▶ Output short circuit protection

2.2 Applicaitons

- ▶ Driving piezo actuators
- ▶ Driving piezo objective scanners

2.3 Order information

- ▶ E53.D——Servo SGS sensor Analog/software input control
Accept customized according to requirements:
 - ① 12bit gain/-20 ~ 120V output voltage (default)
 - ② 15bit gain/-20 ~ 150V output voltage

3. Driving Principle

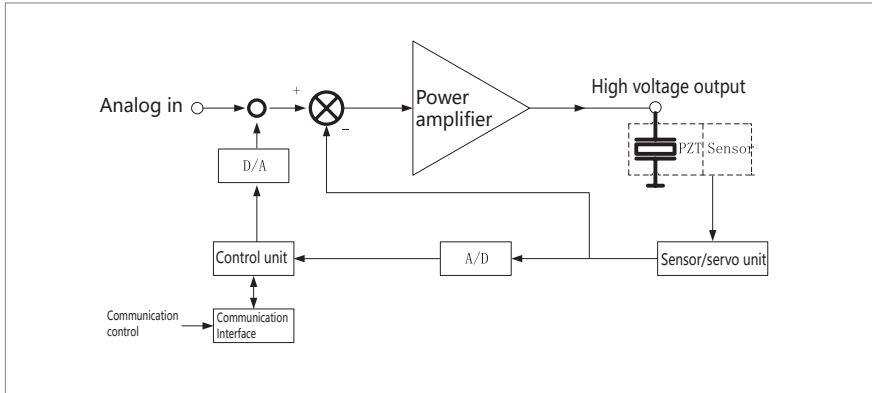

4. Power Calculation

- Average output (Sine wave operation mode)

$$P_a \approx U_{pp} \cdot U_s \cdot f \cdot C_{piezo}$$

P_a =Average output[W]

C_{piezo} =Piezo actuator capacitance[F]

U_{pp} =Peak and peak drive voltage [V]

f =Operating frequency of the sine wave[Hz]

U_s =Drive voltage[V] ($(V_{s+}) - (V_{s-})$)

5. Appearance



6. Panel Introduction

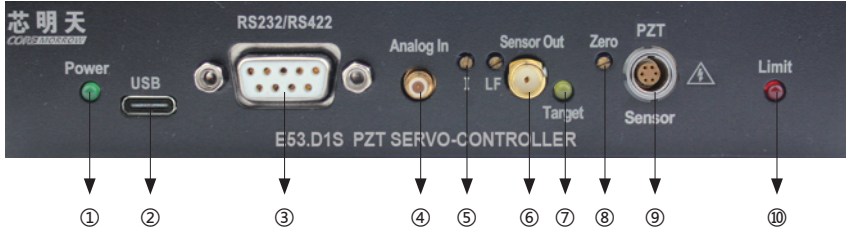

No.	Function	Description
①	Power indicator	Green, lights when power's on
②	USB port	TYPE-C
③	RS-232/422	See interface pin definition
④	Analog input	Analog voltage input interface
⑤	Servo integral	Adjust step response
⑥	Sensor monitor	0 ~ 10V
⑦	Target	Lights when the controlled displacement deviates from the target value
⑧	Zero	Zero adjustment of sensor signal
⑨	PZT&Sensor	PZT&Sensor connector
⑩	Limit	Over-current indicator

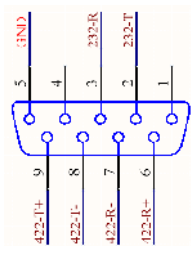

RS-232/422 interface pin definition

PZT & Sensor

No.	Description
1	Sensor+10V power supply
2	Sensor input +
3	Sensor input -
4	Sensor GND
5	High voltage output GND
6	High voltage output +

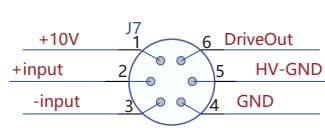

LEMO-ECG-0B-306

7. Notes and suggestions

- ▶ E53.D cannot be used to drive inductive loads. If the inductive loads are driven, the product may be damaged.
- ▶ If there is no need, please do not twist the potentiometer easily.

8. Contact us

Harbin Core Tomorrow Science & Technology Co., Ltd.

Tel: +86-451-86268790

Email: info@coremorrow.com

Website: www.coremorrow.com

Address: Building I2, No.191 Xuefu Road, Nangang District, Harbin, HLJ, China

CoreMorrow Official and CTO WeChat are below:

