



E53.D1E-J/E53.C1K-J Piezo Motor Controller

User Manual



This document describes the following products:

- E53.D1E-J Servo control
- E53.C1K-J Open loop

DECLARATION

Declaration!

This user manual is a integrated user manual of the E53.D1E-J/E53.C1K-J series piezo motor controller. Please read this user manual carefully before using this controller. Follow the instructions in the manual during use. If there is any problem, please contact us for technical support. If you do not follow this manual or disassemble and modify the product yourself, the company will not be liable for any consequences arising therefrom.

Please read the following to avoid personal injury and to prevent damage to this product or any other product connected to it. In order to avoid possible hazards, this product can only be used within the specified range.

Notice!

Do not touch any exposed ends of the product and its accessories.

There is high voltage inside. Do not open the case without permission.

Do not connect or disconnect input, output, or sensor cables with power on.

Please keep surface clean and dry, don't operate in humid or static environment.

After use, output voltage should be cleared to zero before turning off the controller switch, such as switching the servo state to the open-loop state.

Danger!

The piezo motor controller described in this manual is a high-voltage device capable of outputting high currents, which can cause serious or even fatal damage if not used properly.

It is strongly recommended that you do not touch any parts that connect to the high voltage output.

Special Note: If you connect it with other products in addition to our company, please follow the general accident prevention procedures.

Operating the high-voltage amplification requires training professional operators.

Warning!

If the voltage exceeds the PZT's tolerable range, it will cause permanent damage to the PZT. Before adding voltage to the PZT poles, it must be ensured that the positive and negative poles of the PZT are connected correctly and the operating voltage is within the allowable range of this PZT.

Cautious!

E53 housing should be installed on a horizontal surface in an area with a 3CM air flow area to prevent internal convection in the vertical direction.

Insufficient airflow can cause equipment to overheat or premature instrument damage.

Contents

1. Introduction	2
1.1 Features	2
1.2 Applicaitons	2
1.3 Order information.....	2
2.Driving Principle	2
3.Appearance	3
4.Interface	3
4.1 E53.D1E-J&E53.C1K-J.....	3
4.2 Interface definition	4
5.Notes and suggestions	5
6.Contact us	5

1. Introduction

1.1 Features

- ▶ 1 channel small size
- ▶ 24V (20~30V) power supply
- ▶ Peak current 1A
- ▶ Ave current 60mA
- ▶ Unload bandwidth 10KHz
- ▶ Output short circuit protection

1.2 Applicaitons

- ▶ Driving piezo motor

1.3 Order information

- ▶ E53.D1E-J1—— Servo, Software control
 - ▶ E53.C1K-J1—— Open loop, software control
- Accept customized according to requirements.

2. Driving Principle

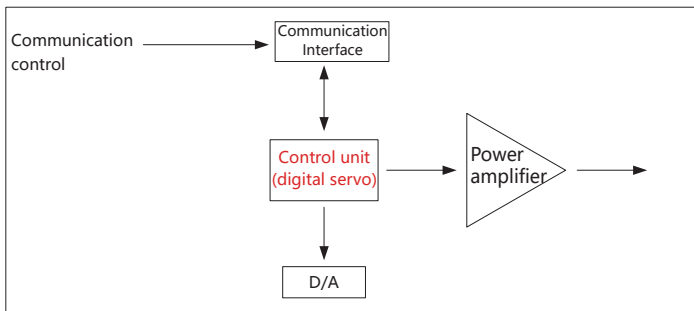

3.Appearance



4.Interface

4.1 E53.D1E-J&E53.C1K-J

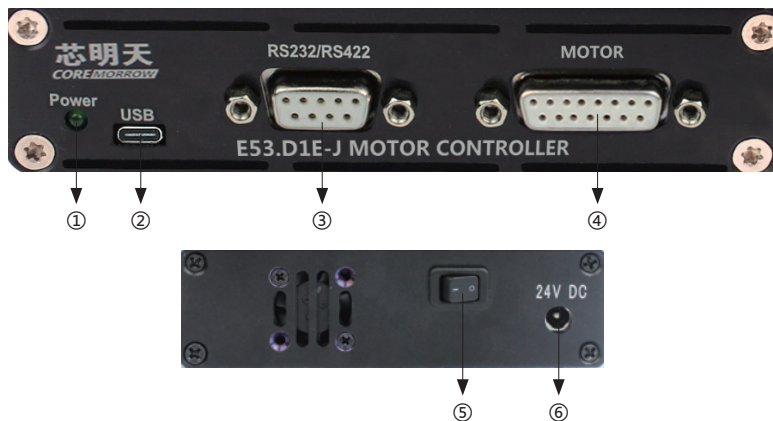

NO	Function	Description
1	Power indicator	Green, lights when power's on
2	USB port	TYPE-C
3	RS23/422	Connect the computer with controller to ctrl by software
4	Connector	Piezo motor connector
5	Power switch	Control the power on and off
6	24VDC	Power supply

4.2 Interface definition

4.2.1 RS232/422

Description	
1	-
2	RS-232-TxD
3	RS-232-RxD
4	-
5	GND
6	RS-422-RxD+
7	RS-422-RxD-
8	RS-422-TxD-
9	RS-422-TxD+

4.2.2 Piezo motor interface definition

NO	Description
8	Differential input signal A-
15	Differential input signal A+
7	Differential input signal B+
14	Differential input signal B-
6	Differential input signal E-(LVDS)
13	CAL signal
5	Differential input signal Z+
12	Differential input signal Z-
4	5V
11	5V_GND
10	GND
1	DriveOut

5. Notes and suggestions

- ▶ E53 cannot be used to drive inductive loads. If the inductive loads are driven, the product may be damaged.
- ▶ If there is no need, please do not twist the potentiometer easily.

6. Contact us

Harbin Core Tomorrow Science & Technology Co., Ltd.

Tel: +86-451-86268790

Email: info@coremorrow.com

Website: www.coremorrow.com

Address: Building I2, No.191 Xuefu Road, Nangang District, Harbin, HLJ, China

CoreMorrow Official and CTO WeChat are below:

